

CX Industrial Cable Gland

Brass gland suitable for wire braid armoured, plastic or rubber sheathed cable. Terminates and secure cable armouring and outer seal grips sheath of cable thus ensuring mechanical strength and earth continuity.

Recommended to use PVC shroud for additional ingress protection.



TECHNICAL DATA

Type	CX
Design Specification	BS 6121 : Part 1 : 1989
Ingress protection	IP66
Gland Material	Brass
Finish	Plain Brass or Nickel Plated
Seal Material	Thermoplastic Elastomer
Cable Type	Wire Braid Armour
Armour Clamping	Three Part (With Lock Nut)
Sealing Technique	Compression Type
Sealing Area	Outer Sheath

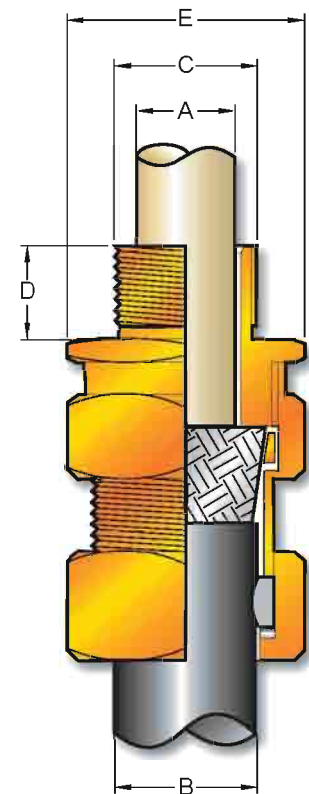

Gland Size	Metric Entry Thread 'C'	Minimum Thread Length 'D'	Under Armour Dia 'A' Max	Overall Dia 'B' Max	Braid Wire Dia	Across Corners Dia 'E' Max	Cat #
16	16	15	6.0	13.2	0.2/0.3	24.4	ACXG-16
20SS	20	15	8.6	13.2	0.2/0.3	24.4	ACXG-20SS
20S	20	15	11.6	15.8	0.2/0.3	26.5	ACXG-20S
20L	20	15	13.9	20.8	0.2/0.3	30.8	ACXG-20L
25S	25	15	15.5	25.8	0.2/0.45	37.0	ACXG-25S
25L	25	15	19.9	27.2	0.2/0.45	38.1	ACXG-25L
32	32	15	26.2	33.5	0.3/0.45	48.0	ACXG-32
40S	40	15	29.4	38.5	0.3/0.45	55.6	ACXG-40S
40L	40	15	32.1	39.9	0.3/0.45	57.7	ACXG-40L
50S	50	15	40.8	51.0	0.3/0.45	58.6	ACXG-50S
50L	50	15	44.0	52.6	0.3/0.45	71.3	ACXG-50L
63S	63	15	50.6	58.9	0.3/0.45	81.3	ACXG-63S
63L	63	15	55.9	65.3	0.3/0.45	88.4	ACXG-63L
75S	75	15	61.9	71.6	0.3/0.45	97.4	ACXG-75S
75L	75	15	67.9	78.0	0.3/0.45	108.0	ACXG-75L
90	90	20	74.0	88.0	0.3/0.45	116.9	ACXG-90

Dimensions in Millimeters